

SCHMIDT® ServoPress / TorquePress Manual Workstation with light curtain (LV)

SCHMIDT® ServoPress / TorquePress manual workstations are delivered ready for operation with press base, transparent protective guarding and light curtain. These systems are single workstations, which can be delivered with all SCHMIDT® ServoPress / TorquePress modules.

Included in the scope of delivery are:

- Module SCHMIDT® ServoPress / TorquePress mounted on a frame
- SCHMIDT® PressControl 5000 with pendant arm system
- Press base PU 10
- Transparent protective guarding with light curtain
- Distance light curtain adjustable in order to ensure a safe distance to the tool.
- Auxiliary control cabinet

All systems are EC type-approved.



Workstations SCHMIDT® ServoPress

With force outputs from 15 N to 150 kN / ounces up to 33,720 lbs.

Complete system with light curtain (LV)

Dimensions – single workstation		405	415 / 416	417	420	450 / 460
B	inch	~ 47.24	~ 47.24	~ 47.24	~ 47.24	~ 47.24
T	inch	~ 35	~ 35	~ 44.88	~ 35	~ 43.31
H	min. inch	74.01	min. 74.01	min. 74.01	min. 103.54	min. 110.63
Working area	inch	~ 33 x 28 x 25	~ 33 x 28 x 25	~ 33 x 28 x 25	~ 33 x 28 x 25	~ 34 x 39 x 26
Ram center – light curtain	inch	12.60	12.99	10.95 – 14.57	12.99 – 16.93	14.57 – 18.50
Weight	approx. lbs	672	683	860	1257	1742

ServoPress No.		405	415/416	417	420	450/460
Frame						
Throat depth	C	inch	5.12	5.12	5.91	6.30
Table bore	D	Ø mm	20H7	20H7	40H7	40H7
Working height	F	inch	9.69	11.81	15.24	20.28
Table height	K	inch	3.66	4.45	5.04	6.10
Table size	B x T	inch	6.30 x 5.51	8.66 x 6.89	9.84 x 7.87	11.81 x 8.66
Mounting surface		inch	6.30 x 13.58	8.66 x 15.94	9.84 x 18.11	11.81 x 22.17
	O	Ø inch	0.35	0.43	0.43	0.51
	SL 1	inch	1.97	3.15	3.15	3.35
	SL 2	inch	8.66	9.84	9.84	11.81
	SL 3	inch				1.97
	SL 4	inch				13.78
	SL 5	inch	12.80	15.35	16.93	20.79
	SL 6	inch	13.58	15.94	18.11	22.17
	SH 1	inch	20.08	24.80	30.71	42.52
	SH 2	inch	40.00	43.31	56.30	72.24
	SB 1	inch	5.51	7.87	8.66	11.02
	SB 2	inch	6.30	8.66	9.84	14.57

Tolerance conversion of typical sizes of SCHMIDT® Presses

Metric	Nominal Inch	Tolerance Inch
20H7	0.7874	-0 / +0.0008
40H7	1.5748	-0 / +0.0010

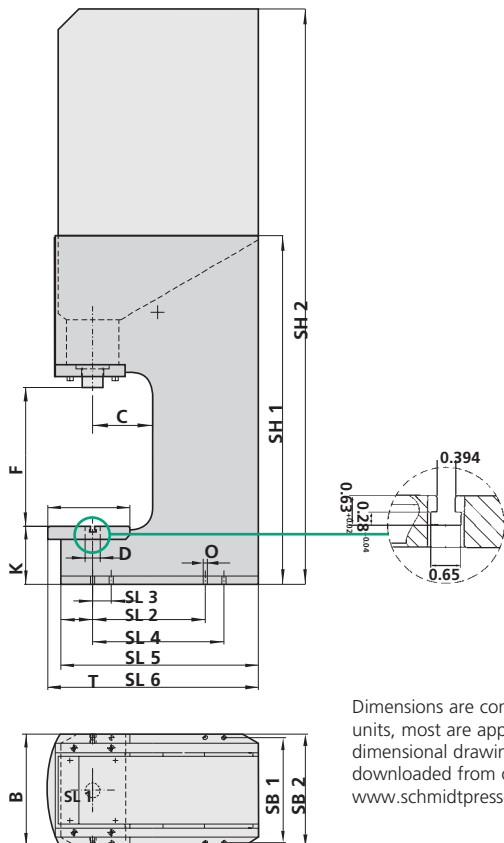

Dimensions are converted from metric units, most are approximate. Detailed dimensional drawings can be downloaded from our website: www.schmidtpresses.com

