

Upper Tool Stud

For Press Nr.
305 & 405 only

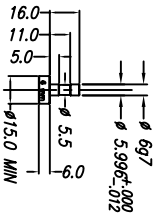

For Press Nr.
307, 311, 415 & 416
and
All Manual Press

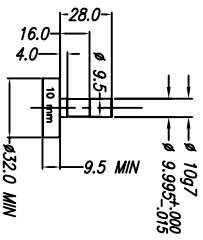

For Press Nr.
19, 20 - 29, 32 - 36,
61, 62, 65 & 68
417, 420, 450 & 460

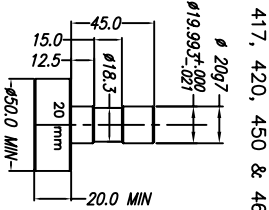

For Press Nr.
64, 74

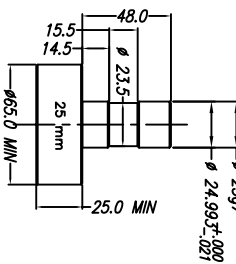

For Press Nr.
76

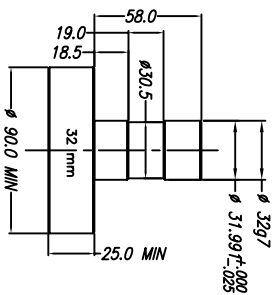

For TT44 Load Cell

For tooling in Loadcell TT-44
with a 10mm shank on press.
Quick Release Pin Pt # P101E145

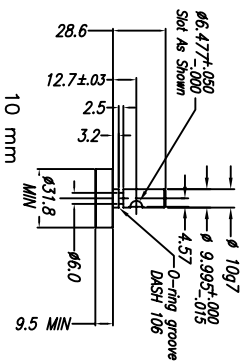

Nest Locating Stud

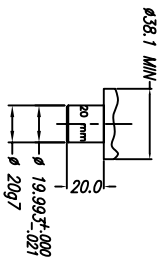

For Press Nr.
All manual 20 - 25
32, 33, 305, 307, 311,
405, 415

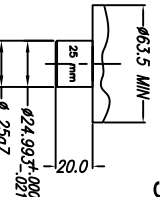

For Press Nr.
27, 34, 61, 62

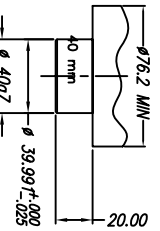

For Press Nr.
29, 36, 68, 64, 74, 76,
417, 420, 450 & 460

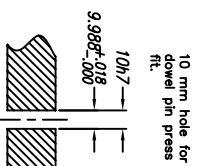

Upper Tool for Rectangular Ram

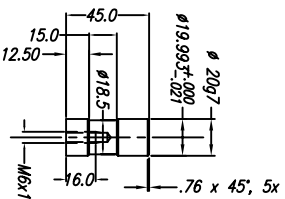

For Press Nr.
61, 62, 65, & 68
34 & 36
323, 327, 361, 362, 365,
& 368
417, 420, 450, & 460

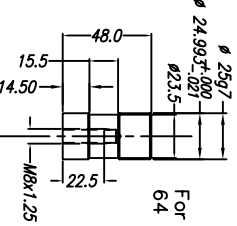

For Press Nr.
64 & 364

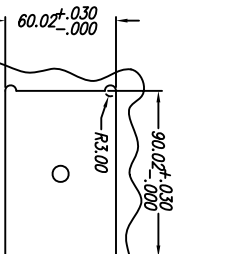

For Press Nr.
64 & 68

For tooling in Loadcell TT-44
with a 32mm shank on press.
Quick Release Pin Pt # P101E146

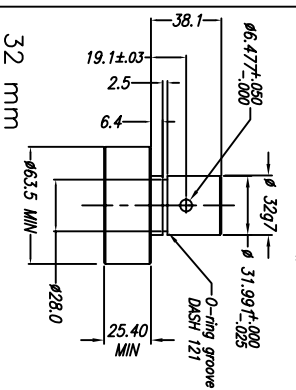

For tooling in Loadcell TT-44
with a 25mm shank on press.
Quick Release Pin Pt # P101E147

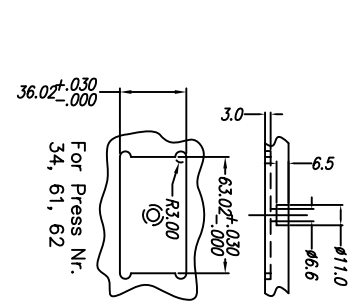
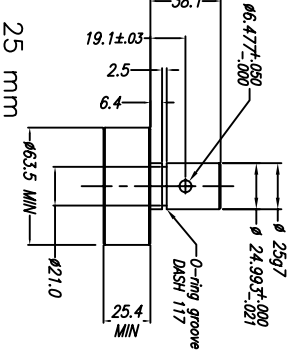

For Press Nr.
34, 61, 62

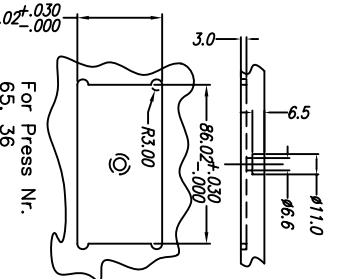

For Press Nr.
65, 36

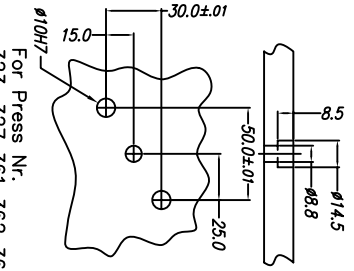

For Press Nr.
323, 327 361 362 364
365 368

MATERIAL:		TREATMENT:	
HEAT TREAT:		TREATMENT:	
TITLE:		CUSTOMER:	
TOLERANCES:		Schmidt Technology Corp.	
DRAWN: TSC		Press Tooling	
DATE: 04/30/09		DATE: 04/30/09	
SCALE: 1:		SIZE: A	
DRAWING NUMBER:		REV:	
Press Tooling Met			

THIS PRINT INDICATES OUR IDEAS. IT IS LOANED SUBJECT TO RETURN ON DEMAND AND UPON THE EXPRESS CONDITION THAT IT WILL NOT BE USED IN ANY WAY DETRIMENTAL TO OUR INTERESTS.



SCHMIDT Technology, Corp. 280 Executive Drive, Cranberry Twp., PA 16066